



EditorsKeys™
Studio Series

INSTRUCTION SHEET

Portable Vocal Booth 'Home' Instruction Sheet

Thank you for choosing the Editors Keys Portable Vocal Booth 'Home' Edition. We're sure you'll love using it, and setup is simple, follow the instructions below in conjunction with your own microphone stand and get perfect vocals every time.

- a. Screen
- b. Sliding Beam
- c. Fixed Screw
- d. Clamp Combination

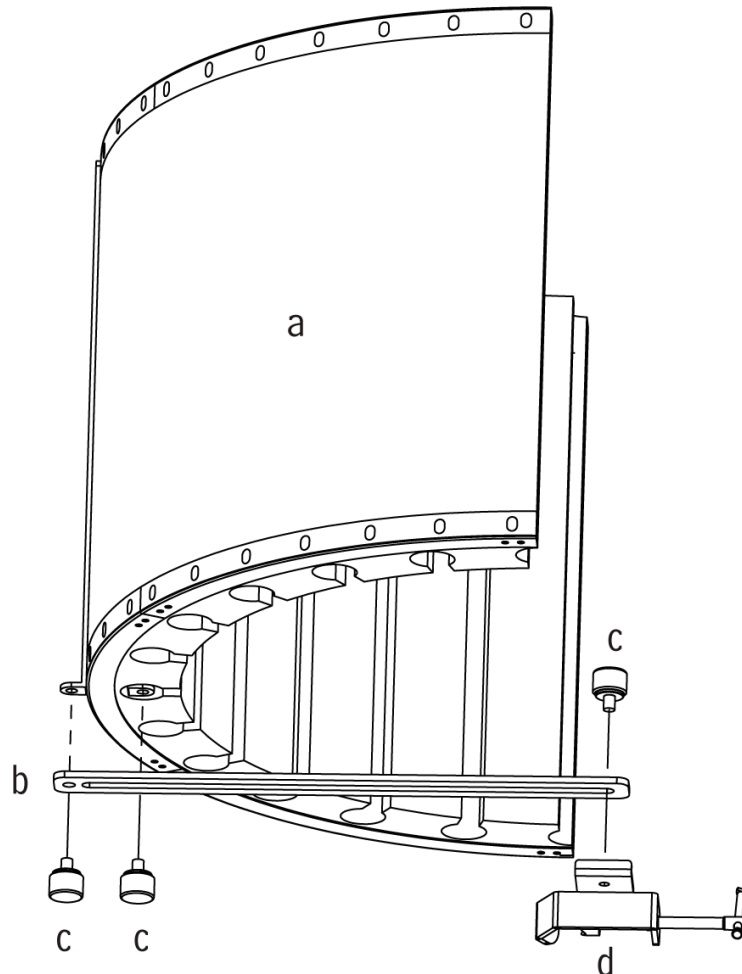

- 1.) Please mount the 'Clamp combination' (d) in a suitable position on your own microphone stand.
- 2.) Screw both 'fixed screws' (c) in order that the 'Sliding Beam' (b) attaches to the 'Screen' (a) tightly. That's it you now have a complete Vocal Booth Screen!
- 3.) Place the Vocal Booth in a suitable position on the 'Sliding Beam' (b), then tighten the 'Fixed Screw' (c).
- 4.) Check the stability of the vocal booth, if the booth feels loose please tighten for safety.

www.editorskeys.com



EditorsKeys™
WWW.EDITORSKEYS.COM

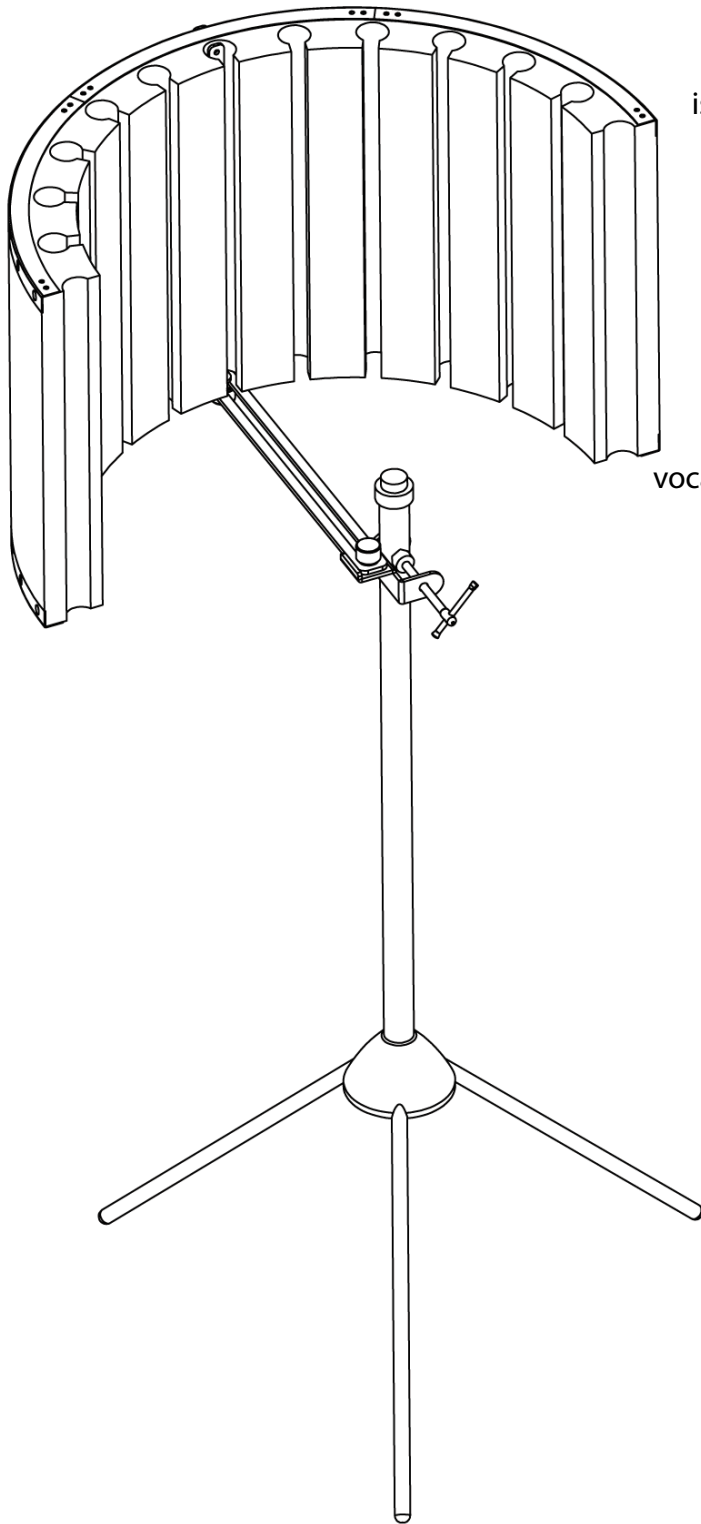

The Portable Vocal Booth 'Home' Edition is an extremely effective acoustic diffusion screen, and is used all over the world, to achieve great vocals in rooms with low or no acoustic treatment.

Its this simple development and structure which has made perfect home recording possible.

We'd love to know how you use your vocal booth, so why not get in touch and send your videos, pictures of recordings. (we may even feature them on the Editors Keys official website.)

www.editorskeys.com